



Wood Window Installation

LINCOLN WOOD PRODUCTS, INC.

These installation instructions are to be used when installing the following Lincoln Windows: Primed Wood Casements, Awnings, Double Hungs, Gliders, Rectangular Direct Sets and Rectangular Sash Sets.

This instruction provides the minimum recommended procedures to correctly prepare the rough opening, install a block frame window unit and apply flashing within a residential or light commercial structure that has the weather resistant barrier applied. Local climate may dictate additional flashing at the discretion of the installer. These instructions are minimal recommendations only and do not supercede local building codes.

Proper installation and maintenance of Lincoln windows is essential to proper window performance. Failure to follow these installation and flashing guidelines may void Lincoln's Limited Warranty. Lincoln recommends installation of its product by experienced contractor personnel. If you have questions regarding window installation, contact your Lincoln dealer, an experienced contractor or contact Lincoln at (800) 967-2461.

Preparing the Rough Opening (R.O.)

CLEARANCE: Lincoln Wood Products Inc. published rough openings allow for a 1/4" of clearance on all sides of the unit for insulation purposes. Use of 1/4" shims on a level sill to provide proper spacing is recommended prior to setting any unit.

MEASURING FOR SQUARE: Take measurements from bottom left corner to top right corner and bottom right corner to top left corner and compare. If measurements are equal the R.O. is square. If measurements are not equal, R.O. is out of square and it is then the responsibility of the installer to remedy this problem (fig. 1).

CHECKING FOR PLUMB: Place a level on both sides of the R.O. making sure the vertical measurement of each side is true. If R.O. is not plumb, it is then the responsibility of the installer to remedy this problem (fig. 1).

CHECKING LEVEL: Place a level on the sill of the R.O. making sure the horizontal measurement on the sill is level. If opening is not level, the use of shims may be used to level the sill (fig. 1).

Note: Unit must be installed square, plumb and level or warranty may be void.

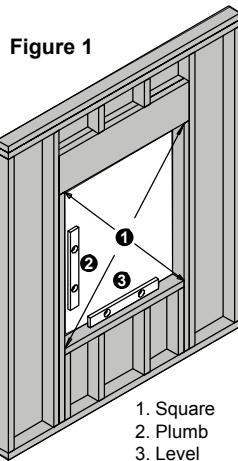

Figure 1

1. Square
2. Plumb
3. Level

Preparing the Weather Resistant Barrier

Draw a modified "I-Cut" with a marker. Start from the top left of the R.O. and continue to the top right of the R.O. making sure mark is flush with rough opening. From the bottom left corner of the R.O. draw a line up approximately 45°. Repeat for opposite side so the two lines intersect. From the middle of the top of the R.O. drop a line vertically so that it intersects with the diagonal lines (fig. 2).

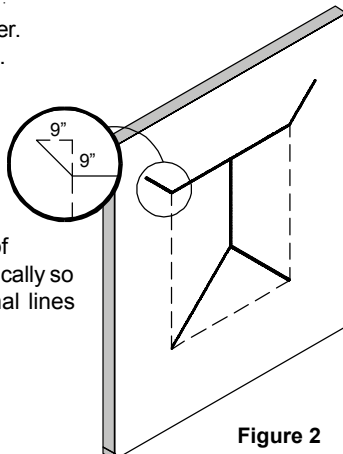

Figure 2

Using a utility knife, cut the lines in the barrier starting with the head and working your way down to create the modified "I-Cut. Fold the bottom and side flaps over and into the interior side of the rough opening. Using staples every 12" to 16" fasten the flaps to the interior and trim excess (fig. 3).

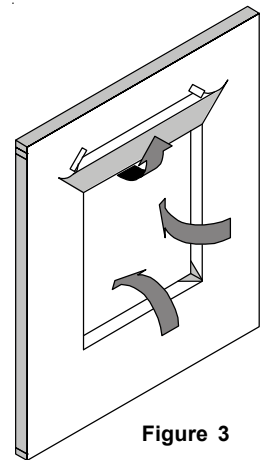

Figure 3

Per ASTM standards Lincoln Wood Products Inc. recommends a minimum of 9" wide flexible flashing. For that reason measure 9" up and 9" over from the top left corner of your rough opening and mark. Repeat on top right corner. A scrap piece of flashing 9" x 9" may be used to simplify this step. Once marked cut the weather barrier diagonally from the top corners of the rough opening to the mark made previously (fig. 2). Fold weather barrier up and tape or tack temporarily out of way (fig. 3).

SILL FLASHING: Flashing can be flexible or adhesive back flexible. All flashing must be at least 9" wide & meet (ASTM D-779; water resistance of at least 24+ hours).

Apply a piece of flashing ① that is 18" longer than the rough opening. Apply sill flashing level with top edge of R.O. allowing 9" of flashing to extend to each side of R.O. (fig. 4).

Figure 4

If using non adhesive flashing fasten the top and sides of the sill flashing with staples located 12" to 16" apart, locate them where they will be covered by the nail flange of the window.

Apply a piece of flashing ② that is cut 12" longer than the rough opening. Apply the flashing so it is flush with the interior edge of the rough sill and notched at the corners to allow the flashing to extend 6" up the jamb (fig. 4).

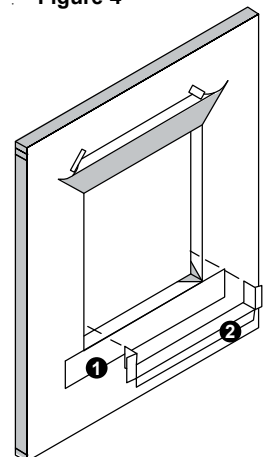

Sill Pan Flashing Installation

Lincoln Wood Products, Inc. recommends the use of sill pan flashing for use under Lincoln primed units. The sill pan flashing should be used in conjunction with flexible flashing per Lincoln's instructions. Failure to comply with these recommendations may void Lincoln's Limited Warranty.

The sill pan flashing is to be the exact size of the sill R.O. with an up turned leg height of 1" on the sides and back of the sill pan. The intersection between the sides and back of the up turned leg must be sealed in a watertight fashion. The front edge of the sill pan should be down turned to seat against the framing material. In some installations, a down turned leg on sill pan will not be necessary.

Before installing sill pan flashing, determine if sill condition is level. If sill is not level, place shims along the length of the sill from jamb to jamb to level sill. Be sure to support the entire sill and not allow it to sag. Rot proof shims are recommended for under sill applications.

Apply two continuous beads of sealant to the rough sill. One on the interior edge the second on the exterior edge. Both are to continue 6" up the R.O. on each side jamb (fig.5). If a shim is necessary place a shim into sealant and apply sealant over the top of the shim. This will insure water will not penetrate under or over the shim (fig.5).

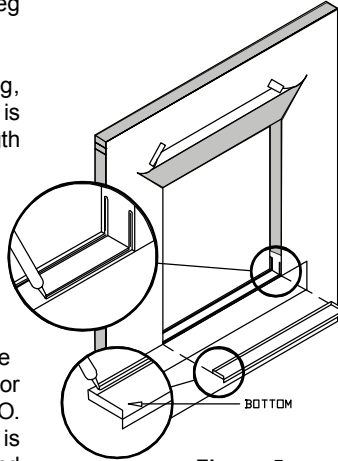

Figure 5

Pre-drill the sill pan at a maximum of 16" between fasteners before it is set into position, and apply a bead of sealant to the back side of the down-turned leg of the sill pan to insure a water tight seal (fig.5).

Place sill pan into position, compressing it down into sealant and over any flexible flashing materials (fig.6).

Check sill pan for level before final installation. Apply sealant to the pre-drilled holes, attach fasteners, and apply sealant over the fastener head (fig.6).

Place a bead of sealant on the interior side of the upturned leg on the inside edge of the sill pan. This will seal the inside edge of the window to the sill pan and not allow any water or air to penetrate to the interior. A second bead of sealant is to be applied in a discontinuous bead on the exterior edge of the sill pan. Allow gaps of 1" to 2" in the sealant every 15" to 18". Continue both beads up the sill pan end cap to insure sealing between the sill pan and side jamb.

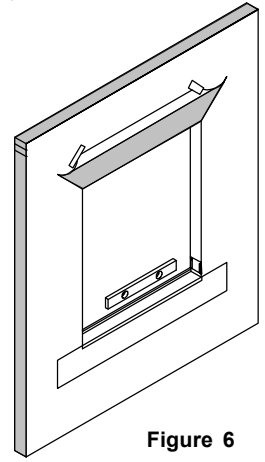

Figure 6

Lincoln Wood Windows may be ordered with or without the exterior casing applied.

If you need to apply the casing in the field, proceed to page 3. If this unit has the exterior casing factory applied, proceed to page 4 for the rest of the instructions.

WINDOW INSTALLATION: FIELD APPLIED CASING

Before installation check window to make sure unit is complete and without defects. If there are any problems with your window contact your Lincoln dealer.

Installation: Set window into sillpan and center it in the R.O. Apply shims as required and check that window is level, plumb, and square (fig7a).

1. Square
2. Plumb
3. Level

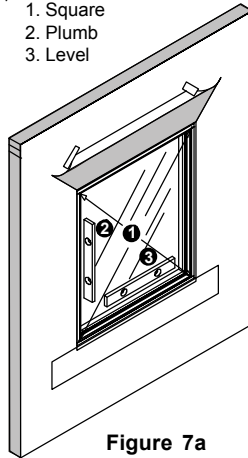

Figure 7a

Fasten one of the upper corners on the side jamb. Check that window is level, plumb, and square. Apply additional shims as needed and continue to attach window into the R.O., continually checking unit for level, plumb, and square. Lincoln Wood Products Inc. recommends the use of fasteners that penetrate window framing a minimum of 1". Stainless or galvanized nails or screws may be used. However, Lincoln Wood Products Inc. does not recommend the use of pneumatic nail guns and will not be responsible for any damaged caused by the use of these nail guns.

NOTE: Unit must be installed square, plumb and level or warranty may be void.

Jamb Flashing: Flashing can be flexible or adhesive back flexible. All flashing must be at least 9" wide and cut so length will extend 8-1/2" beyond the head and sill on both sides of R.O. (R.O. + 17").

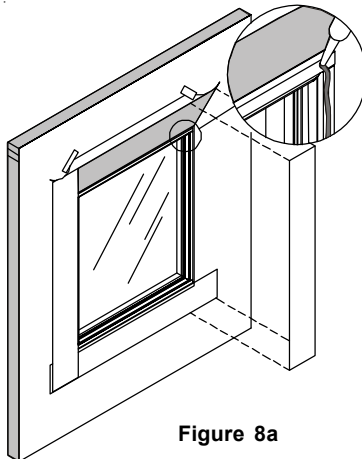

Figure 8a

Apply a continuous vertical bead of sealant approximately 3/8" in diameter to the face of the window frame at the jambs, and attach the jamb flashing to the face of the window frame and over the previously applied sealant (fig8a).

Repeat above steps for jamb flashing on the opposite side of the window unit.

Head Flashing: Flashing can be flexible or adhesive back flexible. All flashing must be a minimum of 9" wide and cut so length is approximately 10" beyond the sides of the R.O. (R.O. + 20"). This will allow the head flashing to overlap the jamb flashing applied earlier.

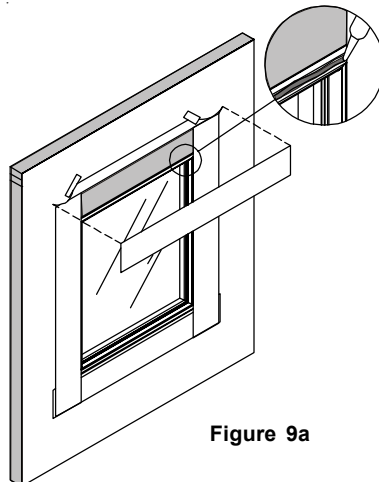

Figure 9a

Apply a continuous horizontal bead of sealant approximately 3/8" in diameter to the face of the window frame at the head, and attach the head flashing to the face of the window frame and over the previously applied sealant (fig9a).

Casing: Apply sealant on the face of the flashing in line with the previously applied sealant, and on the sill horn. Attach the sill nosing, followed by the side casing, and then the head casing (fig10a-12a).

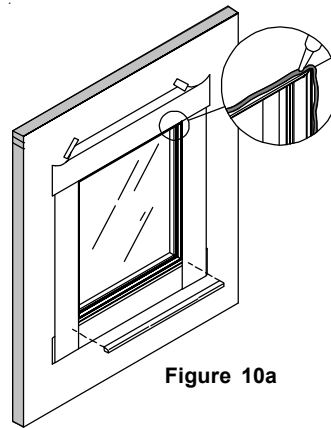

Figure 10a

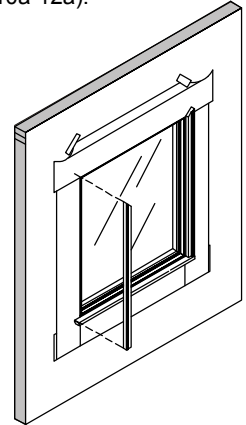

Figure 11a

Rigid Head Flashing: A piece of rigid head flashing is recommended when using casing to assist in the shedding of water away from the unit.

The rigid head flashing must be long enough to run the full length of the head casing, and allow for the ends to be capped (about 1"-1 1/2" longer than the casing). The ends of the rigid head flashing will also need to be cut to fold over the exposed ends of any casing.

Place a bead of sealant on the top of the casing so that the flashing will be set in it. Attach the head flashing with fasteners and place sealant over fastener heads (fig12a).

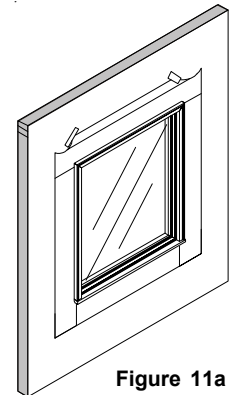

Figure 11a

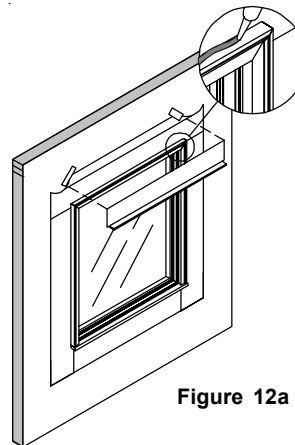

Figure 12a

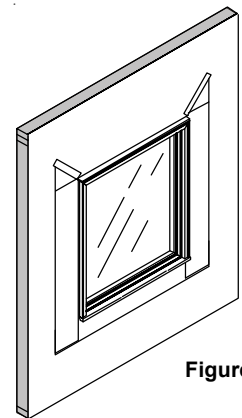

Figure 13a

Place a bead of sealant along the lower part of the upright leg of the rigid head flashing, and fold the weather resistant barrier over the upright leg and compress it into the sealant. Apply sheathing tape over the diagonal cuts in the weather resistant barrier (fig13a).

All exterior wood or cPVC surfaces should be painted and/or sealed immediately after installation.

This completes your window installation.

Failure to follow these recommended instructions may void Lincoln's Limited Warranty.

WINDOW INSTALLATION: FACTORY APPLIED CASING

Before installation check window to make sure unit is complete and without defects. If there are any problems with your window contact your Lincoln dealer.

Jamb Flashing: Flashing can be flexible or adhesive back flexible. All flashing must be at least 9" wide and cut so length will extend 8-1/2" beyond the head and sill on both sides of R.O. (R.O. + 17").

Apply a continuous vertical bead of sealant approximately 3/8" in diameter to the weather resistant barrier and continue the bead 8-1/2" above the R.O. Attach the jamb flashing to the weather resistant barrier and over the previously applied sealant (fig7b).

Repeat above steps for jamb flashing on the opposite side of the window unit.

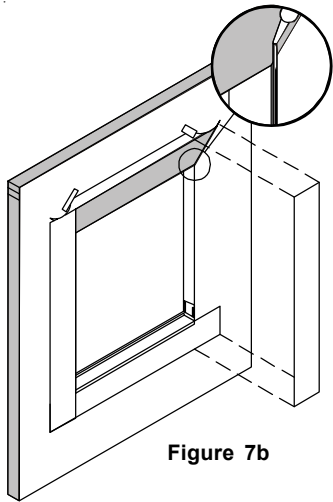

Figure 7b

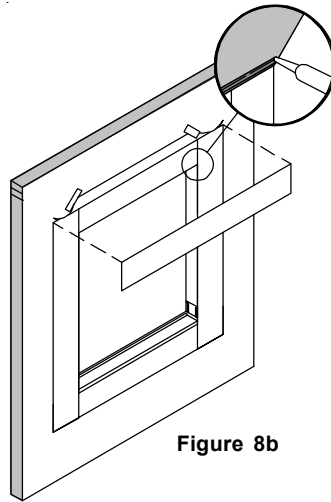

Figure 8b

Head Flashing: Flashing can be flexible or adhesive back flexible. All flashing must be a minimum of 9" wide and cut so length is approximately 10" beyond the sides of the R.O. (R.O. + 20"). This will allow the head flashing to overlap the jamb flashing applied earlier.

Apply a continuous horizontal bead of sealant approximately 3/8" in diameter to the sheathing, and attach the head flashing flush with the R.O. at the head (fig8b).

Casing: Apply a continuous bead of sealant approximately 3/8" in diameter to the backside of the casing prior to setting the unit into position (fig9b).

Installation: Set window into sill pan and center it in the R.O. Apply shims as required and check that window is level, plumb, and square. Fasten one of the upper corners

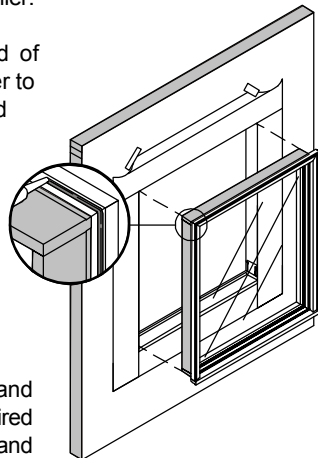

Figure 9b

on the side jamb. Check that window is level, plumb, and square. Apply additional shims as needed and continue to attach window into the R.O., continually checking unit for level, plumb, and square. Lincoln Wood Products Inc. recommends the use of fasteners that penetrate window framing a minimum of 1". Stainless or galvanized nails or screws may be used. However, Lincoln Wood Products Inc. does not recommend the use of pneumatic nail guns and will not be responsible for any damaged caused by the use of these nail guns (fig10b).

NOTE: Unit must be installed square, plumb and level or warranty may be void.

Rigid Head Flashing: A piece of rigid head flashing is recommended when using casing to assist in the shedding of water away from the unit.

The rigid head flashing must be long enough to run the full length of the head casing, and allow for the ends to be capped (about 1"-1 1/2" longer than the casing). The ends of the rigid head flashing will also need to be cut to fold over the exposed ends of any casing.

Place a bead of sealant on the top of the casing so that the flashing will be set in it. Attach the head flashing with fasteners and place sealant over fastener heads (fig11b).

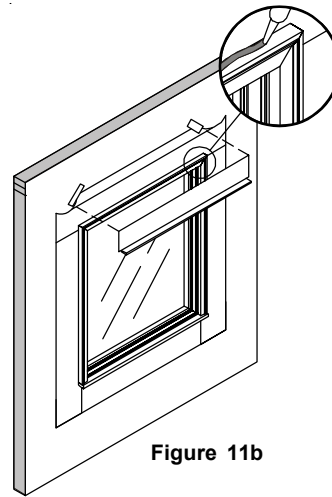

Figure 11b

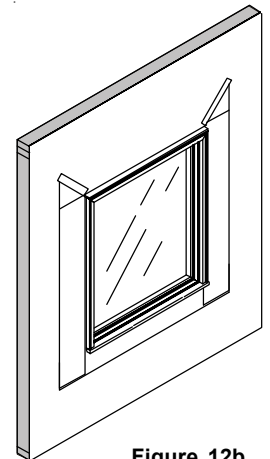

Figure 12b

Place a bead of sealant along the lower part of the upright leg of the rigid head flashing, and fold the weather resistant barrier over the upright leg and compress it into the sealant. Apply sheathing tape over the diagonal cuts in the weather resistant barrier (fig12b).

All exterior wood or cPVC surfaces should be painted and/or sealed immediately after installation.

This completes your window installation.

Failure to follow these recommended instructions may void Lincoln's Limited Warranty.